

# Tumble dryers

## T4530, T4650

### Features and benefits

- High productivity - 2 full loads per hour
- Selection of temperature and time for easy operation
- Large door opening for easy loading and unloading
- Large selfcleaning lint screen for easy maintenance
- Easy access to vital parts from front and rear for simple servicing
- Selecta Microprocessor control
  - 2 auto stop programs for extra dry and dry
  - 5 to 9 tailor made programs for any drying need
  - Accurate temperature control for unmatched drying accuracy
  - Anti-crease cycle for avoiding creasing if the dryer is not unloaded
  - Error codes for easy trouble shooting
  - High contrast display
- Serviceprogram for adjustment of parameters eg. temperature and cooldown time

### Main options

- Stainless steel front
- Stainless steel drum
- Residual Moisture Control - RMC
- Payment: coinmeter, chip card reader, CP connection, intelligent communication
- Reversing drum
- Heat recovery system: Heat Recovery Pipes (HRP)
- Special versions (dryer + option package): Lagoon™ variant includes stainless steel front, stainless steel drum, RMC and reversing drum
- CMIS
- Fresh air intake
- Emergency stop button
- Supply disconnecter



Main specifications			T4530				T4650			
Rated capacity,	filling factor 1:18	kg/lb	29.4/64				36.1/79			
	filling factor 1:25	kg/lb	21.2/46				26/57			
Drum volume		litre	528				650			
Drum diameter		mm	913				913			
Heating alternatives	electric	kW	24/30				30/36			
	gas	BTU/h (kW)	136 500 (40)				194 600 (57)			
	steam at 600-700 kPa	kW	46				46			
<b>Consumption data*</b>			24 kW	30 kW	Gas	Steam	30 kW	36 kW	Gas	Steam
Total time at 23/29.5 kg		min	31	36	22	28	30	36	22	31
Energy consumption at 23/29.5 kg		kWh	14.2	13.7	15	23	16.9	17.4	17.9	28.5
Evaporation		g/min	368	319	524	451	487	414	677	481
Energy kWh/litre water evaporated		kWh/l	1.24	1.2	1.32	1.84	1.16	1.17	1.2	1.91

\* At rated capacity 100% cotton load at 50% initial moisture dried to 0%.

Certified in accordance with ISO 9001 and ISO 14001 and approved IP 42.

Electrical connections				T4530	T4650
Heating Voltage					
El.	200-240V 3AC 50/60 Hz	kW(A)	26 (80)	32 (100)	
		kW(A)	32 (100)	-	
	400-440V 3NAC 50/60 Hz	kW(A)	26 (50)	32 (50)	
		kW(A)	32 (50)	38 (63)	
Gas or steam	230-240V 3AC 50/60 Hz	Motor kW(A)	2 (10)	2 (10)	
	400-440V 3NAC 50/60 Hz	Motor kW(A)	2 (10)	2 (10)	
	230V 1AC 50 Hz	Motor kW(A)	2 (10)	-	
	208-240V 1AC 60 Hz	Motor kW(A)	2 (15)	2 (15)	
	120V 1AC 60 Hz	Motor kW(A)	2 (20)	2 (20)	
Steam, gas and air connections					
Steam	ISO 7/1-R		3/4"	3/4"	
Steam pressure		kPa	100-1000	100-1000	
Steam consumption		kg/h	80-86	80-86	
Condensate	ISO 7/1-R		3/4"	3/4"	
Gas	NG/PG	ISO 7/1-R	1/2"	3/4"	
	TG		1"	-	
Gas pressure	Natural gas	Pa	2000	2000	
		mbar	20	20	
	Propane	Pa	2800-5000	2800-5000	
		mbar	28-50	28-50	
Air outlet		mm	Ø 200	Ø 200	
Evacuated air,	el	m <sup>3</sup> /h	1060	1500	
	steam		1380	1500	
	gas		1160	1500	
Pressure drop (el/steam/gas)	Max.	Pa	200/200/60	340	
Sound levels					
Airborne sound level		dB(A)	<70	<70	
Heat emission					
% of installed power, max			15	15	
Shipping data (el/steam/gas)					
Shipping volume	net, kg		300/340/300	340/345/325	
	crated, kg		315/355/315	355/360/340	
	boxed, kg		455	476	
	crated, m <sup>3</sup>		2.62	3.06	
	boxed, m <sup>3</sup>		2.93	3.68	
Accessories					
Heat recovery pipes			HRP530	HRP530	
Fresh air intake			x	x	
Dimensions in mm					
A	Width		960	960	
B	Depth		1180	1370	
C	Height		1995	1995	
D			720	720	
E			650	650	
F			1725	1725	
G			595	595	
H			155	155	
I			225	225	
J			950	950	
K			2120	2300	
L			1510	1510	
M			270	270	
N			595	595	
O			140	140	
P			170	170	
R			500	500	
S			10	10	
1	Control panel	5	Steam connection		
2	Door opening ø 810	6	Condensate connection		
3	Electrical connection	7	Exhaust connection		
4	Gas connection				

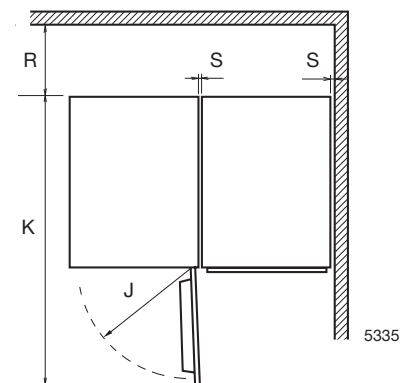
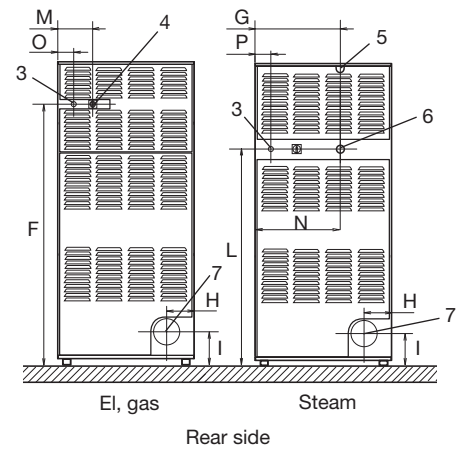
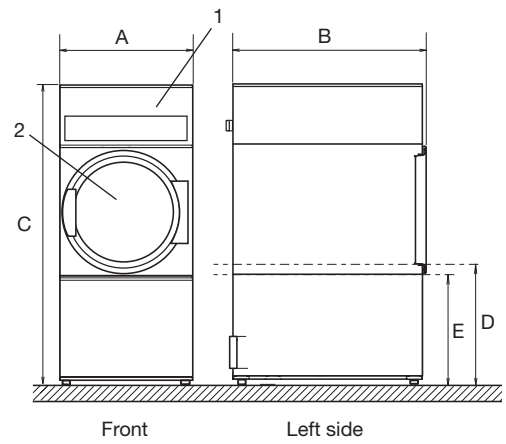

\* Other voltages available, see installation manual.

**Electrolux**

www.electrolux.com/professional

Share more of our thinking at www.electrolux.com

Art. No. 438903201/01 07.04  
We reserve the right to alter specifications without notice.