

Electrical connections*			W4600H	W4850H	W41100H
Heating EI	Voltage				
	230V 3AC 50 Hz	kW(A)	38 (100)	-	-
	230V 3AC 50 Hz	kW(A)	56 (160)	-	-
	240V 3AC 60 Hz	kW(A)	38 (100)	-	-
	240V 3AC 60 Hz	kW(A)	56 (160)	-	-
	400-415V 3N AC 50 Hz	kW(A)	38 (63)	-	-
Steam or non-heated	400-415V 3N AC 50 Hz	kW(A)	56 (100)	-	-
	200V 3AC 60 Hz	kW(A)	-	6.7 (35)	5.3 (35)
	230V 3AC 50 Hz	kW(A)	4 (16)	6.7 (25)	5.3 (25)
	230V 3AC 60 Hz	kW(A)	4 (16)	6.7 (20)	5.3 (20)
	400-415V 3N AC 50 Hz	kW(A)	4 (16)	6.7 (16)	5.3 (16)
Water, steam and air connections					
Water valves	DN		32	40	40
Rec. Water pressure	kPa		200-600	200-600	200-600
Function limits for water valve	kPa		50-1000	50-1000	50-1000
Capacity at 300 kPa	l/min		150	200	200
Drain valve	ø mm		110	110	110
Draining capacity	l/min		400	400	400
Steam valve	DN		20	32	32
Rec. Steam pressure	kPa		300-600	300-600	300-600
Function limits for steam valve	kPa		50-800	50-800	50-800
Compressed air	DN		6	6	6
Air pressure	kPa		500-700	500-700	500-700
Air consumption	l/h		20	20	20
Floor requirements					
Frequency of the dynamic force	Hz		12.7	12.0	11.1
Max floor load at extraction	kN		15.9±6.4	22±7.3	24±7.3
Sound levels					
Sound level	dB(A)		76	73	73
Sound level, with insulation	dB(A)		< 70	< 70	< 70
Heat emission					
% of installed power, max 90°			6	6.7	6.8
Shipping data					
Shipping volume	net, kg m ³		1380 5.7	2200 7.6	2300 8.4

* Other voltages available, see installation manual.

Dimensions in mm		W4600H	W4850H	W41100H
A	Width	1390	1640	1640
B	Depth	1585	1635	1850
C	Height	2015	2230	2230
D		910	995	995
E		300	380	380
F		1865	2135	2135
G		270	1070	1070
H		660	830	830
I		525	635	635
K		425	445	445
L		960	1140	1140
M		1425	1660	1660
N		420	435	435
O		435	820	820
P		2200	2410	2400
R		1120	1175	1160
S		2225	2480	2480
T		935	960	955
U		300	285	240
V		325	400	335

- 1** Control panel
- 2** Door opening \varnothing 700 (W4850H, W41100H), \varnothing 535 (W4600H)
- 3** Soap supply injector, powder (optional)
- 4** Cold water connection
- 5** Hot water connection
- 6** Third water connection (optional)
- 7** Steam connection
- 8** Drain
- 9** Electrical connection
- 10** Compressed air
- 11** External liquid supply, 6 pcs \varnothing 10, 1 pc \varnothing 16 and 1 pc \varnothing 20
- 12** Water connection, soap supply injector (optional)

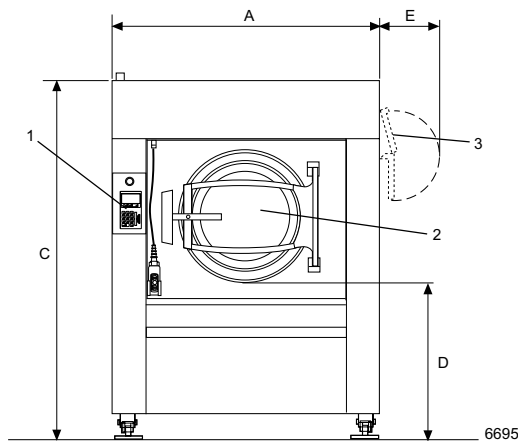

Front

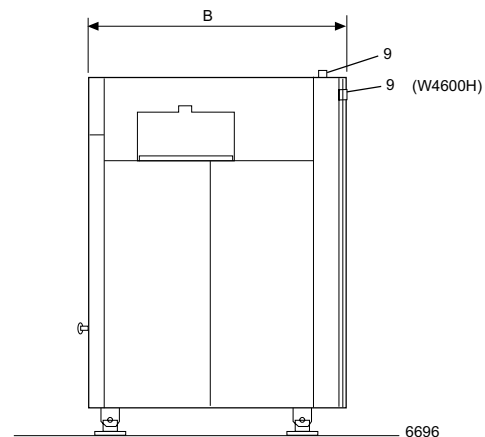

Right side

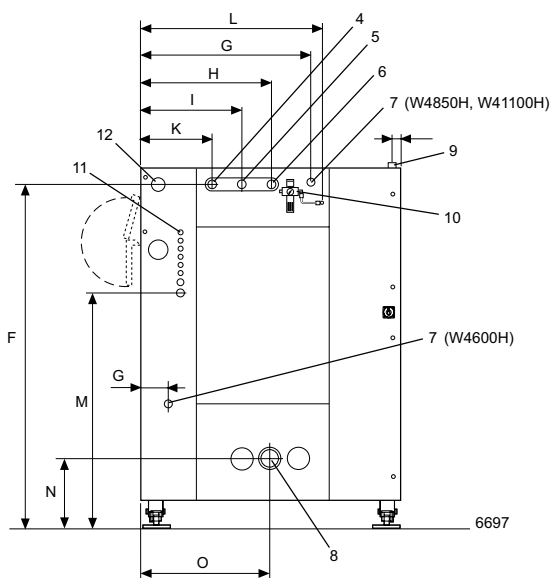

Rear side

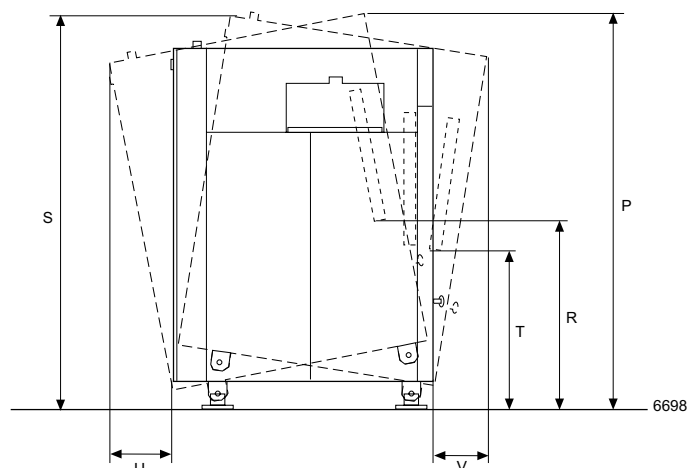

The movement when tilting

Options

- Forward or forward/backward tilting device – for easy unloading with drum reversing into trolley.
- Noise/heat insulation – reduce the airborne sound to less than 70 dB(A).
- Test tap with level tube – gives possibilities to take samples from the wash liquid.
- Water/solvent recovery system – two drain valves to be able to recover water from the rinses and reuse it in the wash.
- Five-compartment supply injector (5x2 litres), right hand side (only W4850H, W41100H).
- Five compartment supply injector (5x1 litre), front mounted (only W4850H, W41100H), front or side mounted (only W4600H).
- Oil lubrication of bearing gaskets with warning for empty container.
- Large water valves (DN 50/2") (not W4600H).
- Connection of intelligent detergent system (DMIS).
- Third water valve - electrically controlled water valve for e.g hard water.
- Connection details for steam.
- Connection details for 2 water.
- Connection details for 3 water.
- Integrated Weighing System (IWS) – shows the weight of the load on the program display.
- Combined steam and electrical heated - gives possibilities to choose between electrical or steam heating by using a switch (only W4600H).
- Water inlet via pump-extra water inlet for water supply controlled by a pump from a recovery system.

Accessory

- Kit for connection to CMIS (Certus Management Information Systems) network. CMIS provides vital statistics, error codes, maintenance intervals, process receipt, etc.



CMIS can be fitted to washer extractors with Clarus Control, tumble dryers with Selecta Control and ironers with electronic control system. All you need to access and view the statistical feedback is a normal PC.